

## About this Manual

We've added this manual to the Agilent website in an effort to help you support your product. This manual is the best copy we could find; it may be incomplete or contain dated information. If we find a more recent copy in the future, we will add it to the Agilent website.

## Support for Your Product

Agilent no longer sells or supports this product. Our service centers may be able to perform calibration if no repair parts are needed, but no other support from Agilent is available. You will find any other available product information on the Agilent Test & Measurement website, [www.tm.agilent.com](http://www.tm.agilent.com).

## HP References in this Manual

This manual may contain references to HP or Hewlett-Packard. Please note that Hewlett-Packard's former test and measurement, semiconductor products and chemical analysis businesses are now part of Agilent Technologies. We have made no changes to this manual copy. In other documentation, to reduce potential confusion, the only change to product numbers and names has been in the company name prefix: where a product number/name was HP XXXX the current name/number is now Agilent XXXX. For example, model number HP8648A is now model number Agilent 8648A.

---

# **HP E2443B Intel Pentium CPU Preprocessor Interface User's Guide**

**for the HP 1660A, HP 16540/16541A,D and HP 16550A Logic Analyzers**

---



©Copyright Hewlett-Packard Company 1993

Manual Part Number E2443-90903  
Microfiche Part Number E2443-90803

Printed in U.S.A. April 1993

## Printing History

---

New editions are complete revisions of the manual. Update packages, which are issued between editions, contain additional and replacement pages to be merged into the manual by the customer. The dates on the title page change only when a new edition is published.

A software code may be printed before the date; this indicates the version of the software product at the time the manual or update was issued. Many product updates and fixes do not require manual changes and, conversely, manual corrections may be done without accompanying product changes. Therefore, do not expect a one to one correspondence between product updates and manual updates.

Edition 1

April 1993

E2443-90903

## List of Effective Pages

---

The List of Effective Pages gives the date of the current edition and of any pages changed in updates to that edition. Within the manual, any page changed since the last edition is indicated by printing the date the changes were made on the bottom of the page. If an update is incorporated when a new edition of the manual is printed, the change dates are removed from the bottom of the pages and the new edition date is listed in the Printing History and on the title page.

**Pages**

**Effective Date**

---

## **Product Warranty**

This Hewlett-Packard product has a warranty against defects in material and workmanship for a period of 1 year from date of shipment. During warranty period, Hewlett-Packard Company will, at its option, either repair or replace products that prove to be defective.

For warranty service or repair, this product must be returned to a service facility designated by Hewlett-Packard. However, warranty service for products installed by Hewlett-Packard and certain other products designated by Hewlett-Packard will be performed at Buyer's facility at no charge within the Hewlett-Packard service travel area. Outside Hewlett-Packard service travel areas, warranty service will be performed at Buyer's facility only upon Hewlett-Packard's prior agreement and Buyer shall pay Hewlett-Packard's round trip travel expenses.

For products returned to Hewlett-Packard for warranty service, the Buyer shall prepay shipping charges to Hewlett-Packard and Hewlett-Packard shall pay shipping charges to return the product to the Buyer. However, the Buyer shall pay all shipping charges, duties, and taxes for products returned to Hewlett-Packard from another country.

Hewlett-Packard warrants that its software and firmware designated by Hewlett-Packard for use with an instrument will execute its programming instructions when properly installed on that instrument.

Hewlett-Packard does not warrant that the operation of the instrument, software, or firmware will be uninterrupted or error-free.

**Limitation of Warranty** The foregoing warranty shall not apply to defects resulting from improper or inadequate maintenance by the Buyer, Buyer-supplied software or interfacing, unauthorized modification or misuse, operation outside of the environmental specifications for the product, or improper site preparation or maintenance.

NO OTHER WARRANTY IS EXPRESSED OR IMPLIED. HEWLETT-PACKARD SPECIFICALLY DISCLAIMS THE IMPLIED WARRANTIES OF MERCHANTABILITY AND FITNESS FOR A PARTICULAR PURPOSE.

**Exclusive Remedies** THE REMEDIES PROVIDED HEREIN ARE BUYER'S SOLE AND EXCLUSIVE REMEDIES. HEWLETT-PACKARD SHALL NOT BE LIABLE FOR ANY DIRECT, INDIRECT, SPECIAL, INCIDENTAL, OR CONSEQUENTIAL DAMAGES, WHETHER BASED ON CONTRACT, TORT, OR ANY OTHER LEGAL THEORY.

**Assistance** Product maintenance agreements and other customer assistance agreements are available for Hewlett-Packard products.

For assistance, contact your nearest Hewlett-Packard Sales and Service Office.

**Certification** Hewlett-Packard Company certifies that this product met its published specifications at the time of shipment from the factory. Hewlett-Packard further certifies that its calibration measurements are traceable to the United States National Bureau of Standards, to the extent allowed by the Bureau's calibration facility, and to the calibration facilities of other International Standards Organization members.

**Safety** This product has been designed and tested according to International Safety Requirements. To ensure safe operation and to keep the product safe, the information, cautions, and warnings in this user's guide must be heeded.

# Contents

---

## Introduction

Logic Analyzer Software Requirement  
Logic Analyzers Supported  
How to Use This Manual

---

## Chapter 1:

### Setting Up the HP E2443B

Introduction . . . . .	1-1
Duplicating the Master Disk . . . . .	1-1
Equipment Supplied . . . . .	1-1
Minimum Equipment Required . . . . .	1-2
Installation Quick Reference . . . . .	1-2
Setting the Switches and Jumpers . . . . .	1-3
Mode of Operation . . . . .	1-3
Clock Qualifier Inputs . . . . .	1-4
Clock Version (Timing Only) . . . . .	1-5
Connecting to the Target System . . . . .	1-7
Connecting to the HP E2443B . . . . .	1-9
Power Up / Down Sequence . . . . .	1-9
Setting Up the Analyzer from the Disk . . . . .	1-11
Timing Analysis . . . . .	1-12

---

## Chapter 2:

### Analyzing the Intel Pentium CPU

Introduction . . . . .	2-1
Format Specification . . . . .	2-1
Symbols . . . . .	2-2
Additional Symbols . . . . .	2-11
Listing Menu . . . . .	2-12
Burst and Cacheable Data . . . . .	2-13
The Pentium CPU Inverse Assemblers . . . . .	2-14
Address Labels . . . . .	2-14
Prefetched Instructions . . . . .	2-15
Synchronizing the Inverse Assembler . . . . .	2-16
Operand Size . . . . .	2-17
Byte Enable Validity . . . . .	2-17
Incomplete Decoding . . . . .	2-17
Opcode Data Numeric Bases . . . . .	2-17
Branch Trace Messaging . . . . .	2-17

Illegal Instructions .....	2-17
The IAPENTE Inverse Assembler .....	2-18
Show/Suppress .....	2-19
Code Synchronization .....	2-19
IDT Description .....	2-19
Modes of Operation .....	2-20
Qualified / Non-qualified Clocking .....	2-20
ClkQual .....	2-21
State Waveforms Using State-Per-Clock Mode .....	2-23

---

## Chapter 3:

### General Information

Introduction .....	3-1
Characteristics .....	3-1
Interface Description .....	3-3
Clocking .....	3-5
Pentium CPU Signal to HP E2443B Connector Mapping .....	3-5
Servicing .....	3-13
Dimensions .....	3-13

---

## Appendix A:

### Troubleshooting

Target Board Will Not Bootup .....	A-1
Bent Pins .....	A-1
"Slow or Missing Clock" .....	A-1
Slow Clock .....	A-2
"No Configuration File Loaded" .....	A-3
"Selected File is Incompatible" .....	A-3
". . . Inverse Assembler Not Found" .....	A-3
No Inverse Assembly .....	A-3
Incorrect Inverse Assembly .....	A-3
No Activity on Activity Indicators .....	A-3
Capacitive Loading .....	A-4
Unwanted Triggers .....	A-4
"Waiting for Trigger" .....	A-4
Intermittent Data Errors .....	A-4
"Time from Arm Greater Than 41.93 ms." .....	A-4
No Setup/Hold Field on Format Screen .....	A-4
"Default Calibration Factors Loaded" (16540/16541A,D) .....	A-4

# Introduction

---

The HP E2443B Preprocessor Interface provides a complete interface for state or timing analysis of a Pentium™ CPU target system by an HP 1660A, HP 16540/16541A,D, or HP 16550A Logic Analyzer.

The Pentium CPU configuration software on the flexible disk sets up the format specification menu of the logic analyzer for compatibility with the Pentium microprocessor. It also loads the inverse assembler for obtaining displays of Pentium CPU data in Pentium CPU assembly language mnemonics.

---

## Logic Analyzer Software Requirement

The HP E2443B Preprocessor Interface requires HP 16500A system and module software version V05.03 or higher (HP 16540/16541A,D and HP 16550A Logic Analyzers). For the HP 16500B mainframe, system and module software version V01.00 or higher is required. For the HP 1660A Logic Analyzer, software version V01.00 or higher is required. To use the enhanced inverse assembler with the HP 1660A Logic Analyzer, software version V02.00 or higher is required. If your software version is older than those listed above, load new system software with the above version numbers or higher before loading the HP E2443B software.

Pentium™ is a trademark of Intel Corporation.



---

## Logic Analyzers Supported

The following logic analyzers are supported by the HP E2443B:

### HP 1660A

The HP 1660A Logic Analyzer provides 4 k of memory depth with 136 channels of 100 MHz state analysis or 250 MHz timing analysis. This logic analyzer also supports various combinations of mixed state/timing analysis.

### HP 16540A,D with three HP 16541A,D Expansion Cards

This logic analyzer combination provides 4 k of memory depth (16 k with the D version) with 160 channels of 100 MHz state or timing analysis.

### HP 16550A (two cards)

This logic analyzer provides 4 k of memory depth with 102 channels per card of 100 MHz state analysis or 250 MHz timing analysis. This logic analyzer also supports various combinations of mixed state/timing analysis.

---

## How to Use This Manual

This manual is organized into three chapters and one appendix:

- Chapter 1 explains how to install and configure the HP E2443B Preprocessor Interface for state or timing analysis with the supported logic analyzers.
- Chapter 2 provides reference information on the format specification and symbols configured by the HP E2443B software. It also provides information about the inverse assemblers and status encoding.
- Chapter 3 contains additional reference information including the characteristics and signal mapping for the HP E2443B Preprocessor Interface. It also contains information on servicing.
- Appendix A contains information on troubleshooting problems or difficulties which may occur with the preprocessor interface.

# Setting Up the HP E2443B

---

## Introduction

This chapter explains how to install and configure the HP E2443B Preprocessor Interface for state or timing analysis with the HP 1660A, HP 16540/16541A,D or HP 16550A Logic Analyzers.

---

## Duplicating the Master Disk

Before you use the HP E2443B software, use the Duplicate Disk operation in the disk menu of your logic analyzer to make a duplicate copy of the HP E2443B master disk. Store the master disk in a safe place and use the back-up copy to configure your logic analyzer. This will help prevent the possibility of losing or destroying the original files in the event the disk wears out, is damaged, or a file is accidentally deleted.

---

## Equipment Supplied

The HP E2443B Preprocessor Interface consists of the following equipment:

- The preprocessor interface hardware, which includes the preprocessor interface circuit card and cables.
  - The configuration and inverse assembly software on a 3.5-inch disk.
  - Two additional jumpers (HP part number 1252-3743).
  - This user's guide.
- 

### Note



The preprocessor interface socket assembly pins are covered at the time of shipment with either a conductive foam wafer or a conductive plastic pin protector. This is done to protect the delicate gold plated pins of the assembly from damage due to impact.

When you're not using the preprocessor interface, protect the socket assembly pins from damage by covering them with the foam or plastic pin protector.

---

---

## Minimum Equipment Required

The minimum equipment required for analysis of a Pentium CPU target system consists of the following:

- An HP 1660A, HP 16540A,D with three HP 16541A,D Expansion Cards, or an HP 16550A (two cards).
- The HP E2443B Preprocessor Interface, which includes the configuration files and inverse assemblers.

---

## Installation Quick Reference

The following procedure describes the major steps required to perform measurements with the HP E2443B Preprocessor Interface. The page numbers listed in the various steps refer you to sections in this manual that offer more detailed information.

---

### Caution

To prevent equipment damage, be sure to remove power from the target system whenever the preprocessor interface or microprocessor is being connected or disconnected.

- 
1. Set the switches and jumpers according to your measurement requirements (see page 1-3).
  2. Install the preprocessor interface in the target system (page 1-7).
  3. Connect the logic analyzer probes to the cable connectors of the preprocessor interface as listed in table 1-3 (see page 1-10).
  4. Load the appropriate logic analyzer configuration file. This also loads the appropriate default inverse assembler file (page 1-11).
  5. If you want to fully capture the execution trace, disable the cache. If possible, you may also want to disable page translation, so the physical addresses the preprocessor interface monitors are effectively the logical addresses (see page 1-8).

---

### Note

Do not disable the cache memory if burst transfers are to be monitored. Enabling the cache memory will allow you to view the data coming across the bus, but the code may not be properly disassembled. Also, when the cache is enabled, unexecuted prefetches are not inferred, and the unexecuted prefetch markers are not displayed.

---

---

## Setting the Switches and Jumpers

The HP E2443B can capture Pentium CPU data in four modes: Timing, State-Per-Clock, State-Per-Transfer, and Debugger modes. Switches 1 and 2 allow you to select the **mode** of operation.

For State-Per-Clock mode, you can also have qualified or non-qualified clocking (selected through the Format menu). State-Per-Transfer and Debugger modes only work in qualified clocking. Switches 3 to 8 select the **clock qualifier inputs** for qualified clocking.

In the Timing mode, you can select a buffered version of the microprocessor clock or a phase-locked loop version. The **clock version** is determined by the location of the jumper on the 1 x 3 header.

## Mode of Operation

In Timing mode, the signals are buffered, but otherwise passed straight through to the logic analyzer. In State-Per-Clock mode, all signals are latched by CLK, and clocked into the logic analyzer each CLK cycle (see Chapter 2 for additional information on State-Per-Clock). In State-Per-Transfer mode, address pipelining is realigned, and only valid transfers are clocked into the logic analyzer. Debugger mode is identical to State-Per-Transfer mode with the exception that, whenever IU, IV or IBT are asserted, data is captured regardless of whether or not it is valid.

Switches 1 and 2 determine the mode of operation (see table 1-1). The LED on the HP E2443B indicates the selected mode of operation.

**Table 1-1. Switch 1 and 2 Settings (Mode of Operation)**

Switch 2	Switch 1	Mode of Operation	LED Color
Off	Off	State-Per-Transfer	Green
Off	On	State-Per-Clock	Amber
On	Off	Timing	Red
On	On	Debugger	Off

## **Clock Qualifier Inputs**

In qualified clocking, the level of a clock qualifier (ClkQual) is ANDed with the edge of the clock (Clk1 on the HP E2443B pod P1), and the resultant rising edge clocks information into the logic analyzer. The clock qualifier equations are listed in Chapter 2.

The logic analyzer must be clocked as qualified for State-Per-Transfer and Debugger modes; it can be clocked as qualified or non-qualified for State-Per-Clock mode.

Note that for State-Per-Clock mode, qualified clocking decreases the number of invalid data/code states which are clocked into the logic analyzer, since only Clk1  $\uparrow$  edges that occur when ClkQual is asserted will be clocked into the logic analyzer. The configuration files set up the logic analyzers for qualified clocking. Use the Format menu to configure the logic analyzer for non-qualified clocking (see Chapter 2).

Switches 3 - 8 select the inputs to the clock qualifier. These switches allow you to select particular cycles or operations to be clocked into the logic analyzer. The inputs to the clock qualifier are selected by closing the appropriate switches. For all switches which are closed, the signals are ORed together to create ClkQual; therefore, closing additional switches increases the variety of states which are clocked into the logic analyzer.

The different clock qualifier inputs are relevant only for certain modes of operation (see table 1-2). For the modes marked "no", the switch position has no effect.

Note that for State-Per-Transfer and Debugger modes, when HLDA or BOFF# is asserted, the preprocessor interface automatically switches to State-Per-Clock mode, regardless of the switch 7 and 8 settings. The State-Per-Clock ClkQual signal becomes relevant. If none of the clock qualifier inputs are selected, then no information will be clocked into the logic analyzer. When HLDA or BOFF# is deasserted, the preprocessor interface automatically switches back to State-Per-Transfer or Debugger mode.

**Table 1-2. Switch 3 - 8 Settings (Clock Qualifier Inputs)**

Relevant for Mode of Operation	Switch 3 BRDY#	Switch 4 BRDYC#	Switch 5 ADS#	Switch 6 EADS#	Switch 7 HLDA	Switch 8 BOFF#
Timing	yes	yes	yes	yes	yes	yes
State-Per-Clock	yes	yes	yes	yes	yes	yes
* State-Per-Transfer	no	no	no	yes ***	**	**
* Debugger	no	no	no	yes ***	**	**

- \* In State-Per-Transfer and Debugger modes, the preprocessor-generated signal "Valid" is also ORed into ClkQual; therefore, valid data-transfer states are always captured. In Debugger mode, all states in which IU, IV, or IBT are asserted are also captured. Valid =  $\neg(BRDY\# \ \& \ BRDYC\#) \ \& \ (\text{Pentium CPU in T2, T12, T2P states})$
- \*\* During State-Per-Transfer and Debugger modes, when HLDA or BOFF# is asserted, the preprocessor interface automatically switches to State-Per-Clock mode, regardless of the switch 7 and 8 settings. The State-Per-Clock clock qualifier inputs become relevant. The HLDA or BOFF# data is not disassembled. When HLDA or BOFF# is deasserted, the preprocessor interface switches back to State-Per-Transfer or Debugger mode; therefore, all other data is still aligned and disassembled.
- \*\*\* For State-Per-Transfer and Debugger modes, pipelined addresses are realigned. The address captured with EADS# is the address of the current bus cycle; it is not the inquire address. However, cache writebacks which are triggered by a snoop will be captured and displayed. To fully capture inquire cycle activity, use State-Per-Clock mode.

**Clock Version (Timing Only)**

The 1 x 3 header serves as a single-pole double-throw switch. It allows you to select the version of the clock which is sent to the logic analyzer in Timing mode. One version of the clock (PLL) is routed through a phase-locked loop, while the other version (CLK) is only buffered. The rising edges of CLK and PLL line up within  $-0.6 \pm .1$  ns, with PLL leading CLK. The factory setting for the jumper is with PLL selected. For more precise timing analysis of the clock signal, the jumper can be moved to the CLK position, so that the buffered version of the clock is captured. The position of this jumper is only relevant for Timing mode.



The load on the clock signal is increased by one 74FCT646A input when the jumper is in the CLK position.

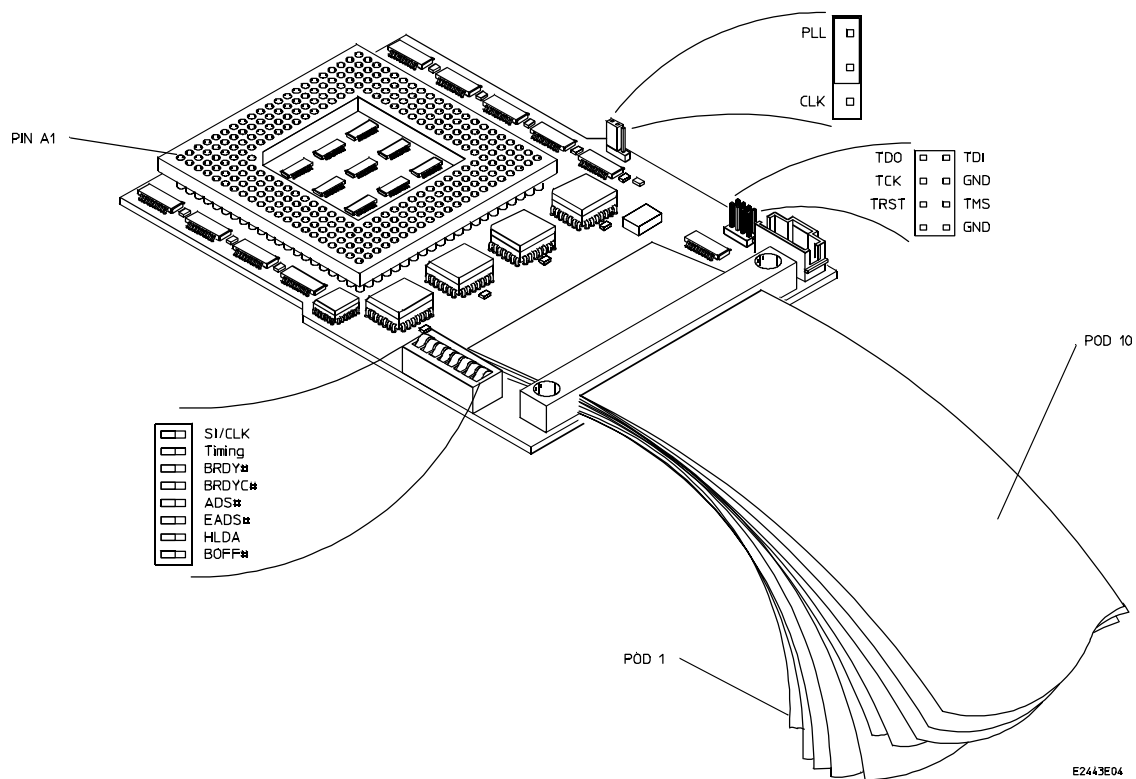

**Figure 1-1. Preprocessor Interface Assembly**

---

## Connecting to the Target System

The following steps explain how to connect the HP E2443B Preprocessor Interface to your target system:

---

**Caution** 

To prevent equipment damage, be sure to remove power from the target system whenever the preprocessor interface or microprocessor is being connected or disconnected.

---

1. Remove the Pentium microprocessor from its socket on the target system and store it in a protected environment.
- 

**Caution** 

Serious damage to the target system or preprocessor interface can result from incorrect connection. Note the position of pin A1 (figure 1-1) on the preprocessor interface connector and the target system socket prior to inserting the connector in the socket. Also, take care to align the preprocessor interface connector with the socket on the target system so that all microprocessor pins are making contact.

---

2. Plug the preprocessor interface connector into the microprocessor socket on the target system.
- 

**Note** 

If the preprocessor interface connector interferes with components of the target system or if a higher profile is required, additional plastic pin guards can be added. Plastic pin guards can be ordered from Hewlett-Packard using the part number 1200-1753. However, any 273-pin PGA IC socket with a Pentium CPU footprint and gold-plated pins can be used.

---

3. Plug the Pentium microprocessor into the socket of the preprocessor interface board. The socket on the preprocessor interface board is designed with low-insertion-force pins to allow you to install or remove the microprocessor with a minimum amount of force.



**Caution** 

---

Care must be used when removing a microprocessor or socket from the preprocessor interface board to prevent damaging the traces on the board.

---

4. If you want to fully capture the execution trace, disable the cache memory. If you leave the cache enabled, all data will still be captured and decoded but you may lose unexecuted-prefetch flagging or synchronization with the execution trace. To capture four-cycle burst transfers you must leave the cache enabled. This will allow you to view all data coming across the bus, although some of the execution trace information will be lost. The cache can be disabled with software by setting CR0.CD, TR12.CI, or the PCD bits in the page table entries to "1". It can be disabled in hardware by deasserting KEN# .

**Note** 

---

If the execution tracing enable bit (bit 1) in TR12.C1 is set to 1, the branch trace message cycles will be captured and decoded by the logic analyzer. This will allow the trace to indicate that branches have occurred, even with the cache enabled.

---

5. If possible, you may want to disable page translation so that the physical addresses that the preprocessor interface monitors are effectively the logical addresses. Page translation can be disabled by setting CR0.PG to zero.

## Connecting to the HP E2443B

Connect the logic analyzer probes to the cable connectors of the preprocessor interface board as listed in table 1-3. Figure 1-2 shows the relative locations of the logic analyzer cards.

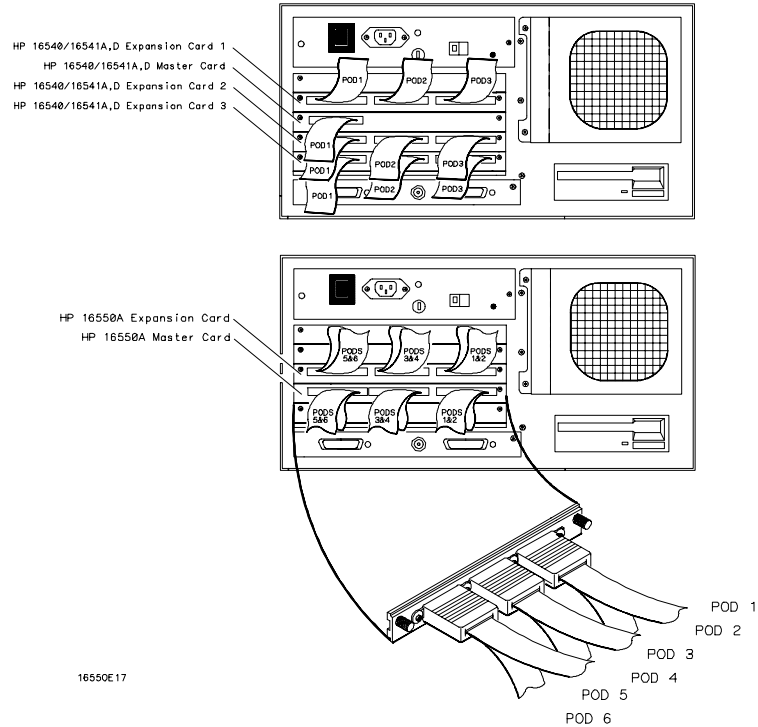

**Figure 1-2. Logic Analyzer Card Locations  
(relative locations, actual slots used can vary)**

## Power Up / Down Sequence

When powering up, the logic analyzer must be powered up first, and then the target system. The logic analyzer provides the power to the active circuits on the preprocessor interface; unpowered circuits may cause improper operation of the target system.

When powering down, power down the target system first, and then the logic analyzer.

**Table 1-3. Connections and Configuration Files**

<b>HP 16540/16541A,D Logic Analyzer Pod *</b>	<b>HP 16550A Logic Analyzer Pod **</b>	<b>HP 1660A Logic Analyzer Pod</b>	<b>(Into)</b>	<b>HP E2443B Connector</b>
Master Card, Pod 1	Master Card, Pod 3	Pod 1		P1 (STAT) Clk1 ↑
Exp. Card 3, Pod 3	Master Card, Pod 4	Pod 2		P2 (STAT)
Exp. Card 3, Pod 1	Master Card, Pod 5	Pod 3		P3 (ADDR)
Exp. Card 3, Pod 2	Master Card, Pod 6	Pod 4		P4 (ADDR)
Exp. Card 2, Pod 1	Expander Card, Pod 1	Pod 5		P5 (DATA)
Exp. Card 2, Pod 2	Expander Card, Pod 2	Pod 6		P6 (DATA)
Exp. Card 1, Pod 1	Expander Card, Pod 3	Pod 7		P7 (DATA_B)
Exp. Card 1, Pod 2	Expander Card, Pod 4	Pod 8		P8 (DATA_B)
Exp. Card 2, Pod 3	Expander Card, Pod 5	--		P9 (additional status)
Exp. Card 1, Pod 3	Expander Card, Pod 6	--		P10 (additional status)
<b>Configuration Files</b>				
CPENT_1	CPENT_2	CPENT_3		

\* For the HP 16541A,D cards, expansion card 1 is the physically highest HP 16541A,D card, expansion card 2 is the second physically highest HP 16541A,D card, and expansion card 3 is the third highest HP 16541A,D card (see fig. 1-2).

\*\* For the HP 16550A cards, the Master Card is the lower card, and the expansion card is the higher card. Note that the two HP 16550A cards must be configured as a single logic analyzer.

---

## Setting Up the Analyzer from the Disk

The logic analyzer can be configured for Pentium CPU analysis by loading the appropriate configuration file. Loading this file will also load a default inverse assembler file (IAPENT or IAPENTE). To load the configuration and inverse assembler:

1. Install the flexible disk in the front disk drive of the logic analyzer. (The HP 16500B mainframe has a hard disk drive. You can create a directory on the hard drive and copy the files from the flexible disk into the directory. For step two, select "Hard Disk.")
2. Select the System Front Disk menu.
3. Configure the menu to "Load" the analyzer configuration from disk.
4. Select the appropriate module (such as "100/500 MHz LA" or "Analyzer") for the load.
5. Use the knob to select the appropriate configuration file (see table 1-3).
6. Execute the load operation to load the file into the logic analyzer.

There are three inverse assemblers in the HP E2443B software. Table 1-4 shows the default inverse assembler which is automatically loaded by the configuration files. It also shows the different logic analyzer configurations which are supported by each inverse assembler. Pages 2-14 and 2-18 contain additional information on the different inverse assemblers.

To load a different inverse assembler after the configuration file has been loaded, repeat steps 1 - 6 above, except that for step 5, select the desired inverse assembler.

**Table 2-4. Inverse Assembler Compatibility**

<b>Logic Analyzer / Mainframe</b>	<b>IAPENT</b>	<b>IAPENTE</b>	<b>IAPENTD</b>
HP 16500A Mainframe	default	no	yes
HP 16500B Mainframe	yes *	default	yes
HP 1660A Logic Analyzer, software V01.xx	default	no	yes
HP 1660A Logic Analyzer, software V02.00 or higher	yes *	default	yes

\* Although this inverse assembler supports these logic analyzers, it does not provide all the features available with IAPENTE.

---

## **Timing Analysis**

The configuration loaded for state analysis may also be used for timing analysis. In Timing mode, the signals are buffered by a 74FCT646AT, with a maximum buffer delay of 6.3 ns (minimum 2.0 ns), and a typical 1.0 ns skew. To configure the logic analyzer for timing analysis:

1. Set the switches for timing (see page 1-3).
2. Load the appropriate configuration file from the disk.
3. Select the Configuration menu of the logic analyzer.
4. Select the Type field and select Timing.

## Analyzing the Intel Pentium CPU

### Introduction

This chapter provides reference information on the format specification and symbols configured by the HP E2443B software. It also provides information about the inverse assemblers and status encoding.

### Format Specification

When you use the HP E2443B Preprocessor Interface, the format specification set up by the software will look similar to that shown in figure 2-1. There are some slight differences in the displays, according to which logic analyzer you are using. Table 3-1 in chapter 3 lists the Pentium CPU signals for the HP E2443B Preprocessor Interface and their corresponding lines to the logic analyzer.



**Note**

The Setup/Hold time must remain in the current setting (4 ns setup/0 s hold for the HP 16540/16541A,D, 3.5 ns setup/0 s hold for the HP 1660A and HP 16550A) for proper operation with the HP E2443B.

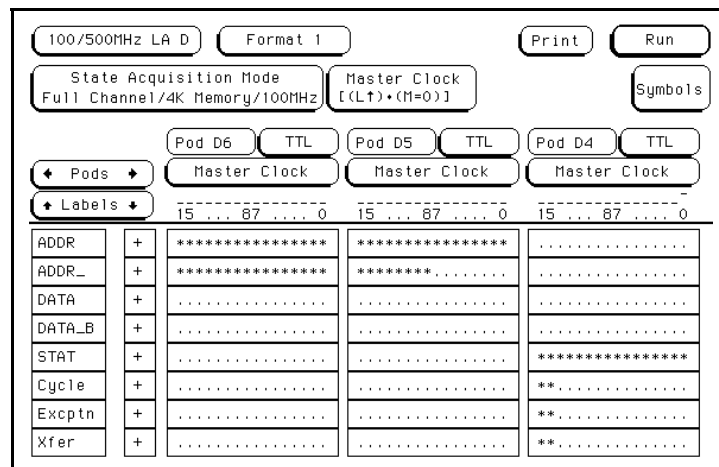

Figure 2-1. Format Specification

---

## Symbols

The configuration files set up symbol tables in the logic analyzer. The tables contain alphanumeric values which identify data patterns or ranges.

Table 2-1 lists the bits in the STAT label. Table 2-2 lists the additional status bits which are available on pods 9 and 10. Table 2-3 lists the additional status bits which are available on the HP 1660A and HP 16550A Logic Analyzers. Table 2-4 lists the signals which are available on the 2 x 4 header. Table 2-5 lists the symbols for the Cycle label. Table 2-6 lists the symbols for the Excpn label, and table 2-7 lists the symbols for the Xfer label. Table 2-8 lists the symbols for BE#. There are also symbols for many of the status signals (listed below table 2-8). The patterns for each symbol listed in the tables are shown in the binary base. In the actual software, these patterns may be listed in the hexadecimal base to conserve display space.

**Table 2-1. STAT Label Bits**

Pod / Bit	Status Signals	Description
P1 / 7 - 0	BE7 - BE0	Byte Enable signals for the data bus.
P1 / 8	IBT	A high indicates a branch was taken.
P1 / 9	KEN#	A low on this signal indicates that the current cycle is cacheable, and will therefore be a burst.
P1 / 10	CACHE#	A low on this signal indicates internal cacheability of the cycle (for reads) or a burst writeback cycle (for writes).
P1 / 11	W/R#	A low indicates read and a high indicates write.
P1 / 12	D/C#	A low indicates a code/special cycle and a high indicates a data cycle.
P1 / 13	M/IO#	A low indicates an I/O cycle and a high indicates a memory cycle.
P1 / 14	LOCK#	A low indicates that the current bus cycle is locked.
P1 / 15	A20M#	A low indicates an Address-bit 20 mask for internal cache lookups or memory cycles.

**Table 2-1. STAT Label Bits (continued)**

<b>Pod / Bit</b>	<b>Status Signals</b>	<b>Description</b>
P2 / 0	Valid	This signal is generated by the preprocessor interface. A high indicates that a data transfer is valid.
P2 / 1	ADS#	A low indicates that a new valid bus cycle is being driven by the Pentium CPU.
P2 / 2	NA#	A low indicates that the external memory is ready to accept a new bus cycle, although all data transfers for the current cycle are not completed.
P2 / 3	BRDY#	A low indicates valid data on the data pins.
P2 / 4	BRDYC#	A low indicates valid data on the data pins for cacheable data.
P2 / 5	PRDY	A high indicates that the Pentium CPU is ready to accept a Probe Mode instruction.
P2 / 6	AHOLD	A high indicates an address hold request.
P2 / 7	EADS#	A low indicates a valid external address has been driven onto the Pentium CPU address pins to be used for an inquiry cycle.
P2 / 8	HIT#	This signal indicates the outcome of the most recent inquire cycle.
P2 / 9	HITM#	A low indicates (during inquire cycles) that a hit to a modified line in the data cache has occurred.
P2 / 13 - 10	BT3 - BT0	Branch target address bits.
P2 / 14	BOFF#	A low indicates that the Pentium CPU should abort all outstanding bus cycles and float its bus on the next cycle.
P2 / 15	HLDA	A high indicates that the Pentium CPU has acknowledged a hold request, and given up the bus.



**Table 2-2. Additional Status Bits**

<b>Pod / Bit</b>	<b>Status Signals</b>	<b>Description</b>
P9 / 0	R/S#	A low indicates that the normal execution of the CPU has been stopped and placed into an idle state, possibly for execution of Boundary Scan/Probe Mode instructions.
P9 / 1	ADSC#	Address strobe used in chip-set mode.
P9 / 2	HOLD	A high indicates a system bus hold request.
P9 / 3	BREQ	A high indicates that the Pentium CPU has internally generated a bus request.
P9 / 4	INTR	A high indicates an external interrupt.
P9 / 5	NMI	A high indicates a non-maskable external interrupt.
P9 / 6	SCYC	A high indicates a split cycle (more than two cycles will be locked together).
P9 / 7	BUSCHK#	A low indicates that the system has unsuccessfully completed a bus cycle.
P9 / 8	FLUSH#	A low indicates that the Pentium CPU will writeback all modified lines and invalidate its cache.
P9 / 9	INV	Indicates the final cache line state for an inquire cycle hit.
P9 / 10	EWBE#	A high (inactive) indicates that a write through cycle is pending in the external system.
P9 / 11	WB/WT#	A low indicates that the current cache line is write-through, and a high indicates write-back.
P9 / 12	PWT	Indicates cache writeback on a page-by-page basis.
P9 / 13	PCD	Indicates cacheability on a page-by-page basis.
P9 / 14	RESET	A high indicates that the Pentium CPU will begin execution from a known reset state.
P9 / 15	INIT	A high indicates that the Pentium CPU will begin execution from a known reset state, except the internal caches and some register values are left unchanged.

**Table 2-2. Additional Status Bits (continued)**

<b>Pod / Bit</b>	<b>Status Signals</b>	<b>Description</b>
P10 / 7 - 0	DP7 - 0	Data parity pins.
P10 / 8	IU	A high indicates that an instruction in the u-pipeline has complete execution.
P10 / 9	IV	A high indicates that an instruction in the v-pipeline has complete execution.
P10 / 10	SMI#	A low indicates a System Power Management interrupt.
P10 / 11	SMIACT#	A low indicates that the Pentium CPU is operating in System Management mode.
P10 / 12	PM0/BP0	BP are the breakpoint pins that indicate a breakpoint match with the debug registers DR3 - 0 when they are programmed as such; the PM are the performance monitoring pins.
P10 / 13	PM1/BP1	
P10 / 14	BP2	
P10 / 15	BP3	

**Table 2-3. Additional Status Bits (HP 1660A and HP 16550A only)**

Pod / Bit	Signals	Description
P3 / Clk1	FERR#	A low indicates that an unmasked floating point error has occurred.
P4 / Clk1	IERR#	A low indicates either an internal parity error or a functional redundancy error.
P5 / Clk1	IGNNE#	A low partially indicates that the Pentium CPU will ignore any pending unmasked numeric exception and continue executing floating point instructions for the entire duration that the signal is asserted.
P6 / Clk1	PEN#	This signal partially determines whether a machine check exception will be taken as a result of a parity error on a read cycle.
P7 / Clk1	PCHK#	This signal indicates the result of a parity check on a read cycle.
P8 / Clk1	AP	Address Parity for the address bus.
P9 / Clk1	* APCHK#	A low indicates a parity error on the address bus.
P10 / Clk1	* FRCMC#	A low indicates that the Pentium CPU has been configured in checker mode, while a high indicates that the Pentium CPU has been configured in master mode.

\* These signals are not available on the HP 1660A Logic Analyzer.



These signals are only available on the HP 1660A and HP 16550A Logic Analyzers. Each signal has its own label in the display.

**Table 2-4. 2 x 4 Header Pins (JTAG)**

<b>Signals *</b>	<b>Description</b>
TCK	Test logic clock signal.
TDI	Test logic serial input.
TDO	Test logic serial output.
TMS	Test logic control signal.
TRST	Test logic reset signal.

\* These signals are located on the 2 x 4 header (see figure 1-1).

The Cycle symbols consist of the following signals, in the designated groupings:

(HLDA BOFF#) (LOCK# M/IO# D/C# W/R#) (BE7-4#) (BE3-0#)

**Table 2-5. Cycle Symbols**

Symbol	Pattern			
HLDA & BOFF	1 0	x x x x	x x x x	x x x x
Hold Ack	1 1	x x x x	x x x x	x x x x
Bus Backoff	0 0	x x x x	x x x x	x x x x
Int Ack 1st	0 1	x 0 0 0	1 1 1 0	1 1 1 1
Int Ack 2nd	0 1	x 0 0 0	1 1 1 1	1 1 1 0
I/O Read	0 1	1 0 1 0	x x x x	x x x x
I/O Write	0 1	1 0 1 1	x x x x	x x x x
Lckd Read	0 1	0 0 1 0	x x x x	x x x x
Lckd Write	0 1	0 0 1 1	x x x x	x x x x
Code Read	0 1	1 1 0 0	x x x x	x x x x
Lckd Code Rd	0 1	0 1 0 0	x x x x	x x x x
Reserved	0 1	x 1 0 1	x x x x	x x x x
Mem Read	0 1	1 1 1 0	x x x x	x x x x
Mem Write	0 1	1 1 1 1	x x x x	x x x x
Lckd Mem Rd	0 1	0 1 1 0	x x x x	x x x x
Lckd Mem Wr	0 1	0 1 1 1	x x x x	x x x x
Shutdown	0 1	x 0 0 1	x x x x	x x x 0
Flush	0 1	x 0 0 1	x x x x	x x 0 x
Halt	0 1	x 0 0 1	x x x x	x 0 x x
Writeback	0 1	x 0 0 1	x x x x	0 x x x
Flush Ack	0 1	x 0 0 1	x x x 0	x x x x
Brch Trg Msg	0 1	x 0 0 1	x x 0 x	x x x x
Undf Special	0 1	x 0 0 1	x x x x	x x x x
---	x x	x x x x	x x x x	x x x x

The Excptn symbols consist of the following signals, in the designated groupings:

(HLDA BOFF#) (D7-0) (M/IO# D/C# W/R#) (BE7-0#)

**Table 2-6. Excptn Symbols**

Symbol	Pattern
Int Ack 1st Cycl	0 1 x x x x x x x x 0 0 0 1 1 1 0 1 1 1 1
0:Divide Error	0 1 0 0 0 0 0 0 0 0 0 0 0 0 0 0 1 1 1 1 1 1 1 0
1:Debug Excptn	0 1 0 0 0 0 0 0 0 0 1 0 0 0 0 1 1 1 1 1 1 1 0
2:NMI Interrupt	0 1 0 0 0 0 0 0 0 1 0 0 0 0 1 1 1 1 1 1 1 0
3:Breakpoint	0 1 0 0 0 0 0 0 0 1 1 0 0 0 1 1 1 1 1 1 1 0
4:INTO Overflow	0 1 0 0 0 0 0 1 0 0 0 0 0 0 1 1 1 1 1 1 1 0
5:BOUND Rng Exc	0 1 0 0 0 0 0 1 0 1 0 0 0 1 1 1 1 1 1 1 1 0
6:Invalid Opcode	0 1 0 0 0 0 0 1 1 0 0 0 0 1 1 1 1 1 1 1 1 0
7:Dev Not Avail	0 1 0 0 0 0 0 1 1 1 0 0 0 1 1 1 1 1 1 1 1 0
8:Double Fault	0 1 0 0 0 0 1 0 0 0 0 0 0 1 1 1 1 1 1 1 1 0
10:Inv Task SSeg	0 1 0 0 0 0 1 0 1 0 0 0 0 1 1 1 1 1 1 1 1 0
11:Seg N/Present	0 1 0 0 0 0 1 0 1 1 0 0 0 1 1 1 1 1 1 1 1 0
12:Stack Fault	0 1 0 0 0 0 1 1 0 0 0 0 0 1 1 1 1 1 1 1 1 0
13:Gen Protectn	0 1 0 0 0 0 1 1 0 1 0 0 0 1 1 1 1 1 1 1 1 0
14:Page Fault	0 1 0 0 0 0 1 1 1 0 0 0 0 1 1 1 1 1 1 1 1 0
16:Flt Point Err	0 1 0 0 0 1 0 0 0 0 0 0 0 1 1 1 1 1 1 1 1 0
17:Alignment Chk	0 1 0 0 0 1 0 0 0 1 0 0 0 1 1 1 1 1 1 1 1 0
---	x x

The Xfer symbols consist of the following signals:

HLDA BOFF# W/R# CACHE# KEN#

**Table 2-7. Xfer Symbols**

<b>Symbol</b>	<b>Pattern</b>
1 Xfer Rd	0 1 0 1 x
1 Xfer Rd	0 1 0 x 1
4 Xfer Rd	0 1 0 0 0
1 Xfer Wr	0 1 1 1 x
4 Xfer Wr	0 1 1 0 x
---	x x x x x

**Table 2-6. BE# Symbols**

Symbol	Pattern
64/b7:0	0 0 0 0 0 0 0 0
32/b3:0	1 1 1 1 0 0 0 0
32/b4:1	1 1 1 0 0 0 0 1
32/b5:2	1 1 0 0 0 0 1 1
32/b6:3	1 0 0 0 0 1 1 1
32/b7:4	0 0 0 0 1 1 1 1
16/b1:0	1 1 1 1 1 1 0 0
16/b2:1	1 1 1 1 1 0 0 1
16/b3:2	1 1 1 1 0 0 1 1
16/b4:3	1 1 1 0 0 1 1 1
16/b5:4	1 1 0 0 1 1 1 1
16/b6:5	1 0 0 1 1 1 1 1
16/b7:6	0 0 1 1 1 1 1 1
8/b0	1 1 1 1 1 1 1 0
8/b1	1 1 1 1 1 1 0 1
8/b2	1 1 1 1 1 0 1 1
8/b3	1 1 1 1 0 1 1 1
8/b4	1 1 1 0 1 1 1 1
8/b5	1 1 0 1 1 1 1 1
8/b6	1 0 1 1 1 1 1 1
8/b7	0 1 1 1 1 1 1 1
None	1 1 1 1 1 1 1 1
---	x x x x x x x x

**Additional Symbols**

There are also symbols for the following signals: KEN#, CACHE#, W/R#, D/C#, M/IO#, LOCK#, SCYC, IBT, IV, IU, WB/WT#, PWT, PCD, BUSCK#, FLUSH#, IERR#, INTR, NMI, SMI#, SMIAC#, A20M#, AP, APCHK#, ADS#, AHOLD, BOFF#, BRDY#, BRDYC#, EADS#, EWBE#, HIT#, HITM#, HLDA, HOLD, INV, NA#, BREQ, RESET, INIT, PEN#, PCHK#, FERR#, IGNNE#, PRDY, and R/S#.



## Listing Menu

Captured data is displayed as shown in figure 2-2 (with the IAPENT inverse assembler) or figure 2-3 (with the IAPENTE inverse assembler). The inverse assemblers are constructed so the mnemonic output closely resembles the actual assembly source code. In figure 2-3, the unexecuted prefetches have been suppressed.

The logic analyzers always probe the full 64-bit data bus of the Pentium CPU. When fewer than the full 64 bits of the data bus are used by a memory cycle, the inverse assembler marks the bytes not used by the microprocessor with "xx."

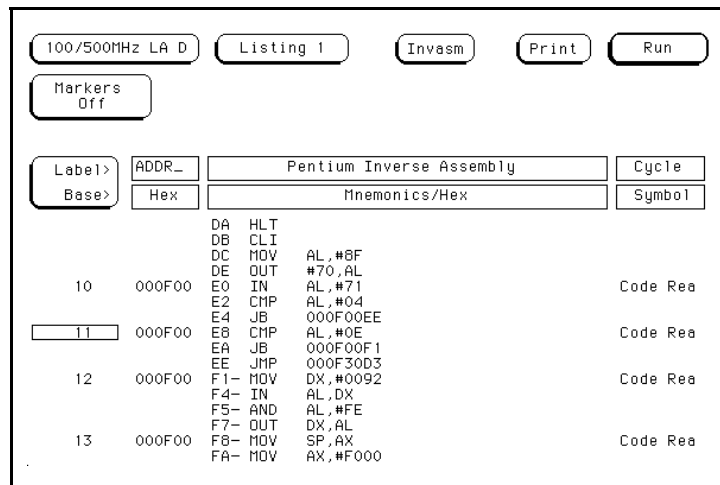

The screenshot shows a software interface for the IAPENT Inverse Assembler. At the top, there are several buttons: "100/500MHz LA D", "Listing 1", "Invasm", "Print", and "Run". Below these is a "Markers Off" button. The main display area is a table with columns for "Label", "Base", "ADDR", "Pentium Inverse Assembly", "Mnemonics/Hex", "Cycle", and "Symbol". The table contains several rows of assembly instructions, with some rows highlighted in blue. The instructions include HLT, CLI, MOV, OUT, IN, CMP, JB, JMB, JMP, MOV, IN, AND, OUT, and MOV.

Label	Base	ADDR	Pentium Inverse Assembly	Mnemonics/Hex	Cycle	Symbol
			DA	HLT		
			DB	CLI		
			DC	MOV AL,#8F		
			DE	OUT #70,AL		
10		000F00	E0	IN AL,#71		Code Rea
			E2	CMP AL,#04		
			E4	JB 000F00EE		
11		000F00	E8	CMP AL,#0E		Code Rea
			EA	JB 000F00F1		
			EE	JMP 000F30D3		
12		000F00	F1	MOV DX,#0092		Code Rea
			F4	IN AL,DX		
			F5	AND AL,#FE		
			F7	OUT DX,AL		
13		000F00	F8	MOV SP,AX		Code Rea
			FA	MOV AX,#F000		

Figure 2-2. State Listing, IAPENT Inverse Assembler

100/500MHz LA D		Listing 1	Invasm Options	Print	Run
Markers Off					
Label>	ADDR_	Pentium Inverse Assembly			Cycle
Base>	Hex	Mnemonics/Hex			Symbol
		DA	HLT		
		DB	CLI		
		DC	MOV AL,#8F		
		DE	OUT #70,AL		
10	000F00	E0	IN AL,#71		Code Rea
		E2	CMP AL,#04		
		E4	JB 000F00EE		
11	000F00	E8	CMP AL,#0E		Code Rea
		EA	JB 000F00F1		
		EE	JMP 000F30D3		
14	000000	70	xxxxxxxx xxxxxx8F i/o write		I/O Writ
19	000000	71	xxxxxxxx xxxxFFxx i/o read		I/O Read
20	000F30	D3	=MOV EDI,EAX		Code Rea
		D6	=MOV ESI,EAX		
21	000F30	D9	=SHL ESI,#10		Code Rea
		DD	=MOV ECX,EDX		

**Figure 2-3. State Listing, IAPENTE Inverse Assembler (Unexecuted Prefetches Suppressed)**

### Burst and Cacheable Data

The logic analyzer can track burst (4-transfer) and non-burst (1-transfer) cycles. During burst transfers the microprocessor holds the address constant during the entire burst. The inverse assembler listing displays the two least significant hexadecimal digits of the actual address (derived by the inverse assembler) at the left side of the column.

Up to eight instructions may be displayed for a single analyzer state, because the Pentium CPU fetches eight instruction bytes from program memory. If the first byte of these eight bytes contains a single-byte instruction, the next sequential instruction begins in the next higher byte. This process continues from the least significant byte to the most significant byte until all of the fetched bytes are used. When a single state contains more than one instruction, each instruction is displayed on a separate line.

---

## The Pentium CPU Inverse Assemblers

The HP E2443B Preprocessor Interface software contains three inverse assemblers. There are two default inverse assemblers, IAPENT and IAPENTE, and a data-mode inverse assembler, IAPENTD. IAPENTE contains additional features which use the increased capabilities of some of the logic analyzers (only available with the HP 16500B mainframe, and the HP 1660A Logic Analyzer with software version V02.00 or higher). For more information on the IAPENTE features, see "The IAPENTE Inverse Assembler" in this chapter.

The default inverse assemblers analyze the microprocessor code and disassemble it into Pentium CPU mnemonics, which are displayed on the logic analyzer screen. Unexecuted prefetches are marked with a hyphen (-).

The data-mode inverse assembler (IAPENTD) functions like the default inverse assemblers, except that it does not decode instructions or mark unused prefetches. IAPENTD is useful for examining data flow, while IAPENT or IAPENTE are useful for examining instruction flow. You can also store data, and re-examine it later using a different inverse assembler.

The inverse assemblers only work in State-Per-Transfer and Debugger modes. They do not work in State-Per-Clock or Timing modes.

### Address Labels

Two different address labels are provided, ADDR and ADDR\_. ADDR provides the full 32 address bits (A31:0), while ADDR\_ provides the upper 24 address bits (A31:8).

When using the inverse assembler, use ADDR\_ in the listing. ADDR\_ gives you the upper 24 bits of the address, while the inverse assembler display gives you the lower eight address bits (A7:0) in its first two columns. Using these two fields together gives you the entire 32 address bits.

The ADDR label displays the actual (acquired) 32-bit address, with A2:0 = 000 binary. When the inverse assembler is turned off, the ADDR field can be used to display the full address in hexadecimal format.

## **Prefetched Instructions**

The Pentium CPU microprocessor is a prefetching microprocessor. It may prefetch up to 64 bytes (eight 64-bit code fetches) before the current opcode. When a program executes an instruction that causes a branch, the prefetched code is not used and will be discarded by the microprocessor. The inverse assembler marks unused prefetches with a hyphen "-" in the third column of the display.

The logic analyzer captures prefetches, even if they are not executed. Therefore, care must be taken when you are specifying a trigger condition or a storage qualification and the instruction of interest follows an instruction that may cause branching. An unused prefetch may generate an unwanted trigger.

The Pentium CPU has a prefetch queue of essentially 64 bytes. This means that by the time a branching instruction is fully decoded, up to 64 other instruction bytes may have already been prefetched across the data bus, and stored in the logic analyzer. Both exceptions and instructions can cause the prefetch queue to be flushed and subsequently refilled. Branches, jumps, calls, returns, and system control instructions are the most common causes of prefetch queue flushes, but there are many others. Refer to your Pentium CPU user's manual for more information.

## Synchronizing the Inverse Assembler

In some cases the prefetch marking algorithm in the inverse assembler may lose synchronization, and unused prefetches or executed instructions may be incorrectly marked. If you suspect that the inverse assembler has lost synchronization, re-synchronize the inverse assembler by pointing to an executed instruction. Once synchronized, the inverse assembler will disassemble from this state through the end of the screen. To point to an executed instruction:

1. Select a line on the display that you know contains the first byte of an executed instruction.
2. Roll this line to the top of the listing.



---

The cursor location is not the top of the listing. In figure 2-2, the instruction DA HLT is the top of the listing.

---

3. For the IAPENT or IAPENTD inverse assemblers, select the "Invasm" field at the top of the display. A pop-up appears with the following choices:

Size 16 Byte 0/8	Size 32 Byte 0/8
Size 16 Byte 1/9	Size 32 Byte 1/9
Size 16 Byte 2/A	Size 32 Byte 2/A
Size 16 Byte 3/B	Size 32 Byte 3/B
Size 16 Byte 4/C	Size 32 Byte 4/C
Size 16 Byte 5/D	Size 32 Byte 5/D
Size 16 Byte 6/E	Size 32 Byte 6/E
Size 16 Byte 7/F	Size 32 Byte 7/F

For the IAPENTE inverse assembler, select the "Invasm Options" button, and use the "Code Synchronization" portion of the submenu.

Size, as used here, refers to the default operand size for this code (16 or 32 bits).

4. Select the choice that identifies which byte of the captured state contains the first byte of the code fetch and what the default operand size is for this code (16 or 32 bits). With the IAPENTE inverse assembler, also select "Align".

Rolling the screen up will inverse assemble the lines as they appear on the bottom of the screen. If you jump to another area of the acquisition buffer by entering a new line number, you may have to re-synchronize the inverse assembler by repeating steps 1 through 4.

**Operand Size** The "=" symbol is displayed in the fourth column of the inverse assembly display for 32-bit operands. The "= " symbol will appear for default 32-bit operand operations, as well as for operations when the operand size prefix is encountered and decoded.

**Byte Enable Validity** The Byte Enables are not valid during cache accesses (bursts). Since all cache reads and writes must be 64 bits, all data lines are valid during these cycles.

**Incomplete Decoding** If a complete opcode is not present, the inverse assembler will not be able to decode it. A pair of asterisks "\*" will be listed on the display.

**Opcode Data Numeric Bases** Most data is displayed in hexadecimal format. An exceptions is the operand for the INT value, which is displayed in decimal. Decimal numbers are indicated by a "d" suffix.

**Branch Trace Messaging** The Pentium CPU inverse assemblers decode branch trace messages, which gives you branch target addresses. This is especially useful for tracing execution while operating out of cache.

**Illegal Instructions** When the inverse assembler decodes an illegal instruction, the message "Illegal Opcode" is displayed, along with the byte(s) which caused the decoded illegal opcode. This message is often an indication that the inverse assembler has lost synchronization (see page 2-16).

**Note** 

---

Do not modify the ADDR, DATA, DATA\_B, or STAT labels in the format specification if you want inverse assembly. Changes may cause incorrect results. Also note that if the trace specification is modified to store only selected bus cycles, incorrect or incomplete inverse assembly may result.

---

---

## The IAPENTE Inverse Assembler

The IAPENTE inverse assembler contains additional features which use the increased capabilities of some of the logic analyzers. It supports the HP 16540/16541A,D and HP 16550A Logic Analyzers in the HP 16500B mainframe, and the HP 1660A Logic Analyzer with software version V02.00 or higher. For those logic analyzer systems, the IAPENTE inverse assembler is automatically loaded when the appropriate configuration file is loaded. Note that all the features in the IAPENTE inverse assembler are also included in the IAPENTE inverse assembler (see previous section).

The IAPENTE Inverse Assembly Options menu contains three functions: display filtering with Show/Suppress selections, Code Synchronization, and IDT description entry (see figure 2-4). The following sections describe these functions.

---

### Note

If the X or O pattern markers are turned on, and the designated pattern is found in a state that has been Suppressed with display filtering, the following message will appear on the logic analyzer display: "X (or O) pattern found, but state is suppressed."

---

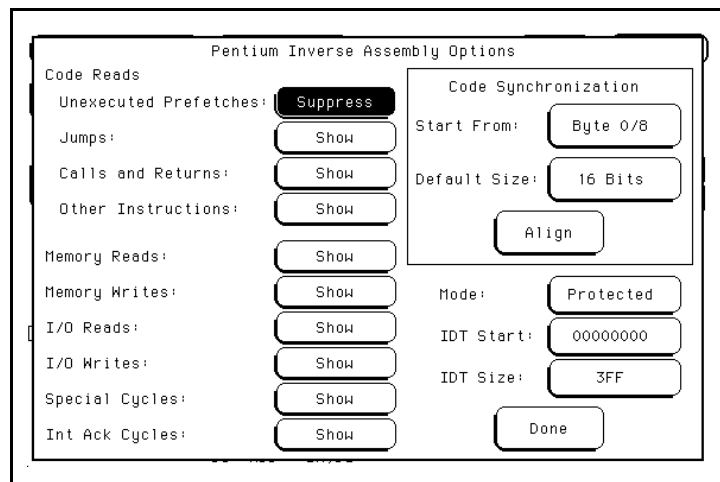

Pentium Inverse Assembly Options	
<b>Code Reads</b>	
Unexecuted Prefetches:	<input type="button" value="Suppress"/>
Jumps:	<input type="button" value="Show"/>
Calls and Returns:	<input type="button" value="Show"/>
Other Instructions:	<input type="button" value="Show"/>
Memory Reads:	<input type="button" value="Show"/>
Memory Writes:	<input type="button" value="Show"/>
I/O Reads:	<input type="button" value="Show"/>
I/O Writes:	<input type="button" value="Show"/>
Special Cycles:	<input type="button" value="Show"/>
Int Ack Cycles:	<input type="button" value="Show"/>
<b>Code Synchronization</b>	
Start From:	<input type="button" value="Byte 0/8"/>
Default Size:	<input type="button" value="16 Bits"/>
	<input type="button" value="Align"/>
Mode:	<input type="button" value="Protected"/>
IDT Start:	<input type="button" value="00000000"/>
IDT Size:	<input type="button" value="3FF"/>
	<input type="button" value="Done"/>

Figure 2-4. IAPENTE Inverse Assembly Options

**Show/Suppress** The Suppress/Show settings determine whether the various microprocessor operations are shown or suppressed on the logic analyzer display. Figure 2-4 shows the microprocessor operations which have this option. The settings for the various operations do not affect the data which is stored by the logic analyzer, they only affect whether that data is displayed or not. The same data can be examined with different settings, for different analysis requirements.

This function allows faster analysis in two ways. First, unneeded information can be filtered out of the display. Figure 2-4 shows the settings to suppress unexecuted prefetches. Figure 2-3 (page 2-13) shows a listing with the unexecuted prefetches suppressed, so that only executed instructions are displayed. A comparison of figures 2-2 and 2-3 shows the difference in the listing display.

Second, particular operations can be isolated by suppressing all other operations. For example, I/O accesses can be shown, with all other operations suppressed, allowing quick analysis of I/O accesses.

**Code Synchronization** The Code Synchronization enables the inverse assembler to resynchronize with the microprocessor code. In some cases the prefetch marking algorithm in the inverse assembler may lose synchronization, and unused prefetches or executed instructions may be incorrectly marked. If any of the Code Reads are suppressed, this could cause some executed instructions to be missing from the display.

To resynchronize the inverse assembler, use the procedure on page 2-16.

**IDT Description** The IDT Description settings include Mode, IDT Start, and IDT Size. Mode can be Protected, Real, or Virtual. IDT Start refers to the starting address of the Interrupt Descriptor Table, and IDT Size refers to the size of the table. Set these functions to match the target system settings.

In most cases, the inverse assembler can automatically determine the target system settings, and will operate properly regardless of the settings entered. The inverse assembler uses the information from these settings only in cases of uncertainty. If you suspect that the inverse assembler is disassembling improperly, check that these settings match your target system.



---

## Modes of Operation

The HP E2443B can capture Pentium CPU data in four modes; Timing, State-Per-Clock, State-Per-Transfer, and Debugger. In Timing mode, the signals are buffered, but otherwise passed straight through to the logic analyzer; in State-Per-Clock mode, all signals are latched by CLK, and clocked into the logic analyzer each CLK cycle. This allows the logic analyzer to capture wait states and idle states, in addition to valid data states. In State-Per-Transfer and Debugger modes, address pipelining is realigned, and only valid data transfers are clocked into the logic analyzer. Debugger mode is identical to State-Per-Transfer mode with the exception that, whenever IU, IV or IBT are asserted, data is captured regardless of whether or not it is valid.

Timing mode also allows a choice of buffered or phase-locked loop clocks (see Chapter 1). Chapter 1 shows the switch settings for selecting the different modes of operation.

## Qualified / Non-qualified Clocking

In non-qualified clocking, Clk1  $\uparrow$  (on the HP E2443B pod P1) is used to clock information into the logic analyzer. In qualified clocking, only those edges of Clk1  $\uparrow$  that occur when ClkQual is asserted will clock information into the logic analyzer. Therefore, qualified clocking allows you to filter information, since ClkQual must be asserted before the logic analyzer is clocked by Clk1  $\uparrow$ .

The logic analyzer must use qualified clocking for State-Per-Transfer and Debugger modes; it can be clocked as qualified or non-qualified for State-Per-Clock mode. With non-qualified clocking, every state is captured, regardless of the settings for the switches. The configuration file sets up the logic analyzer for qualified clocking.

To change to non-qualified clocking, use the Format menu to remove the clock qualifier. The clock qualifier is the M Clock on the HP 16550A, and the K Clock on the HP 16540/16541A,D and HP 1660A Logic Analyzers. Figure 2-5 shows the Format specification with the clock qualifier removed. Only the L Clock (Clk1) is shown in the Master Clock field. Clk1 is the L clock in the HP 16550A ; it is the J clock in the HP 1660A and HP 16540/16541A,D.

**ClkQual** In State-Per-Clock mode, six signals can be used as inputs to the clock qualifier (see Chapter 1). The inputs are selected by closing the appropriate switches. The only states which will be captured are those in which the signal for a selected (closed) switch is asserted. The equation for the clock qualifier in State-Per-Clock mode is:

$$\begin{aligned} \text{ClkQual} = & \quad ![(\text{BRDYsel} \ \& \ !\text{BRDY}\#) \ \text{or} \ (\text{BRDYCsel} \ \& \ !\text{BRDYC}\#) \\ (\text{St-Pr-Clk}) & \quad \text{or} \ (\text{ADSsel} \ \& \ !\text{ADS}\#) \ \text{or} \ (\text{EADSsel} \ \& \ !\text{EADS}\#) \\ & \quad \text{or} \ (\text{HLDAsel} \ \& \ \text{HLDA}) \ \text{or} \ (\text{BOFFsel} \ \& \ !\text{BOFF}\#)] \end{aligned}$$

In State-Per-Transfer and Debugger modes, the preprocessor-generated signal "Valid" is part of ClkQual. One additional signal (EADS#) can be used as an input to the clock qualifier, by closing the switch. In addition, in Debugger mode data is captured whenever IU, IV, or IBT are asserted.

Whenever BOFF# or HLDA is asserted, the preprocessor interface automatically switches to State-Per-Clock mode, and the State-Per-Clock ClkQual becomes relevant. There are five additional signals which can be used in the State-Per-Clock ClkQual. If none of the switches are closed, no information will be clocked into the logic analyzer as long as BOFF# or HLDA is asserted. This allows maximum flexibility of logic analyzer storage and filtering when the Pentium CPU is tri-stated.

Note that information is not inverse assembled while the preprocessor interface is in State-Per-Clock mode. When BOFF# or HLDA is deasserted, the preprocessor interface switches back to State-Per-Transfer or Debugger mode.

The equations for the State-Per-Transfer and Debugger clock qualifiers are:

$$\text{Valid} = \quad ![(\text{BRDY}\# \ \& \ \text{BRDYC}\#) \ \& \ (\text{Pentium CPU in T2, T12, T2P states})]$$

$$\text{ClkQual (St-Pr-Tr)} = \quad ![(\text{Valid}) \ \text{or} \ (\text{EADSsel} \ \& \ !\text{EADS}\#)]$$

$$\text{ClkQual (Debugger)} = \quad ![(\text{Valid}) \ \text{or} \ (\text{EADSsel} \ \& \ !\text{EADS}\#) \ \text{or} \ \text{IU} \ \text{or} \ \text{IV} \ \text{or} \ \text{IBT}]$$

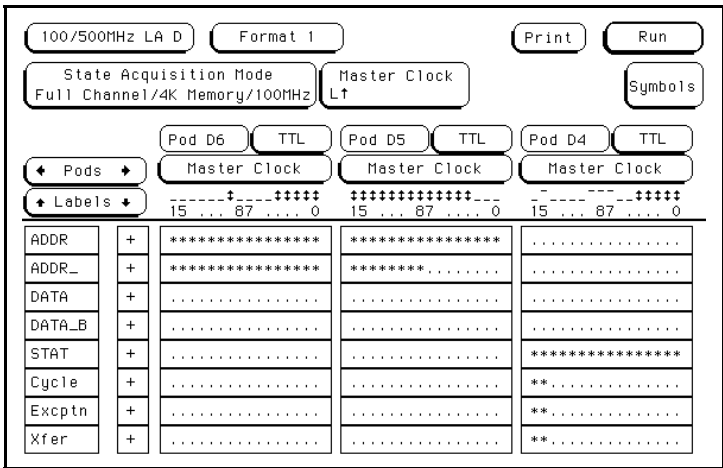

Figure 2-5. Clock Qualifier Removed From Master Clock

# State Waveforms Using State-Per-Clock Mode

The State-Per-Clock mode can be used with the State Waveforms function of the logic analyzer to produce state timing diagrams. The horizontal axis displays state transitions rather than absolute time.

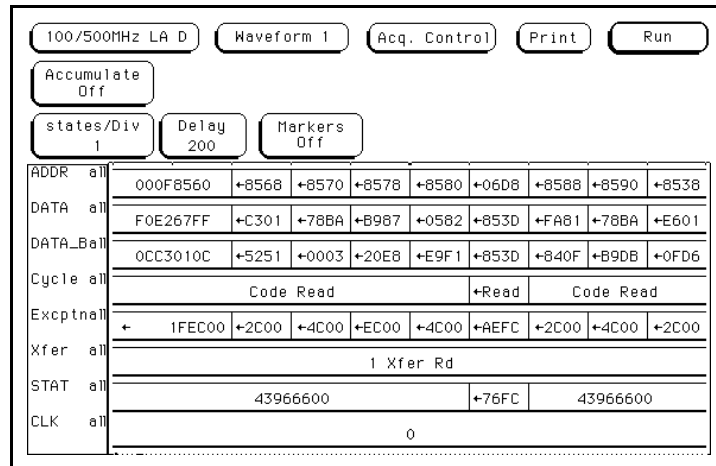

Figure 2-6. State Waveforms

## General Information

---

### Introduction

This chapter contains additional reference information including the characteristics and signal mapping for the HP E2443B Preprocessor Interface.

---

### Characteristics

The following operating characteristics are not specifications, but are typical operating characteristics for the HP E2443B Preprocessor Interface. These characteristics are included as additional information for the user.

<b>Microprocessor Compatibility:</b>	Intel Pentium CPU.
<b>Microprocessor Package:</b>	273-pin PGA.
<b>Accessories Required:</b>	None.
<b>Maximum Clock Speed:</b>	66 MHz CLK
<b>Target Signal Timing:</b>	A minimum 3.5 ns setup/1.5 ns hold is required on the data bus. A minimum 4.5 ns setup/1.5 ns hold is required on all other signals.
<b>Signal Line Loading:</b>	7 pf in series with 85 ohms on CLK 14 pf in series with 35 ohms on the following signals: ADS# , BOFF# , BRDY# , BRDYC# , HLDA, KEN# , W/R# 14 pf on the following signals: IU, IV, IBT, INIT, TDO, SMIACT# , R/S# , and RESET. 10 pf on all other signals.
<b>Power Requirements:</b>	1.5 A at + 5 Vdc maximum from the logic analyzer.
<b>Logic Analyzer Required:</b>	HP 1660A, HP 16540A,D with three HP 16541A,D Expansion Cards, or HP 16550A (two cards).
<b>Number of Probes Used:</b>	Ten 16-channel pods are available (a 17th channel is available for the HP 1660A and HP 16550A Logic Analyzers). Eight pods are required for inverse assembly.

**Microprocessor Operations Displayed:** Interrupt Acknowledge  
 All Special Cycles (including Branch Trace Messages)  
 I/O Reads, Writes  
 Code Reads  
 Data Reads, Writes  
     Normal Reads  
     Pipelined Loads  
     Page Directory Reads, Writes  
     Page Table Reads, Writes  
     Write Throughs  
     Store Misses  
     Write Backs  
 Interrupt Acknowledge Cycles

**Additional Capabilities:** The logic analyzer captures all bus cycles, including prefetches. Unexecuted prefetches are marked with a dash "-".

The State-Per-Clock mode offers filtering for valid data (BRDY#), valid address (ADS#), inquire address (EADS#), DMA (HLDA), and bus arbitration (BOFF#).

**Environmental**

**Temperature:** Operating: 0 to + 55° C  
 (+ 32 to + 131° F)  
 Nonoperating: -40 to + 75° C  
 (-40 to + 167° F)

**Altitude:** Operating: 4,600 m (15,000 ft)  
 Nonoperating: 15,300 m (50,000 ft)

**Humidity:** Up to 90% noncondensing. Avoid sudden, extreme temperature changes which could cause condensation within the instrument.

---

## Interface Description

The primary function of a preprocessor interface is to connect the target microprocessor to the logic analyzer through the probe interface, and to perform any functions unique to that particular microprocessor. The HP E2443B Preprocessor Interface performs this primary function in the following ways:

- By latching and buffering the addresses, data, and status of the Pentium microprocessor so that address, status, and data can be sent to the logic analyzer at the same time.
- By generating the logic analyzer clocks and clock qualifiers from the appropriate Pentium microprocessor signals and bus conditions.

All Pentium CPU signals are buffered/latched by the Registered Transceivers (see figure 3-1). One method of capture is used for State-Per-Transfer mode, while a different method is used for State-Per-Clock and Debugger modes. The Pipeline Register Mux controls the method of capture.

In State-Per-Transfer and Debugger modes, KEN# , WB/WT# , and all signals which follow address timing are also routed through the Stage 2 flip flops. The Pipeline Register Mux selects either Stage 1 (Registered Transceivers) or Stage 2 data, depending on the current depth of the pipeline. The parent address is stored by the preprocessor interface until all of its associated data has crossed the bus. When the Control/Clocking PALs determine that the data is valid, they assert ClkQual and the properly-aligned data and address are captured by the logic analyzer. The preprocessor interface will align all possible permutations of pipeline depth and burst transfers.

In State-Per-Clock mode, the Registered Transceivers are configured as flip flops; in Timing mode, they serve as buffers. For both modes, the Pipeline Register Mux routes the output from the Registered Transceivers directly to the logic analyzer.

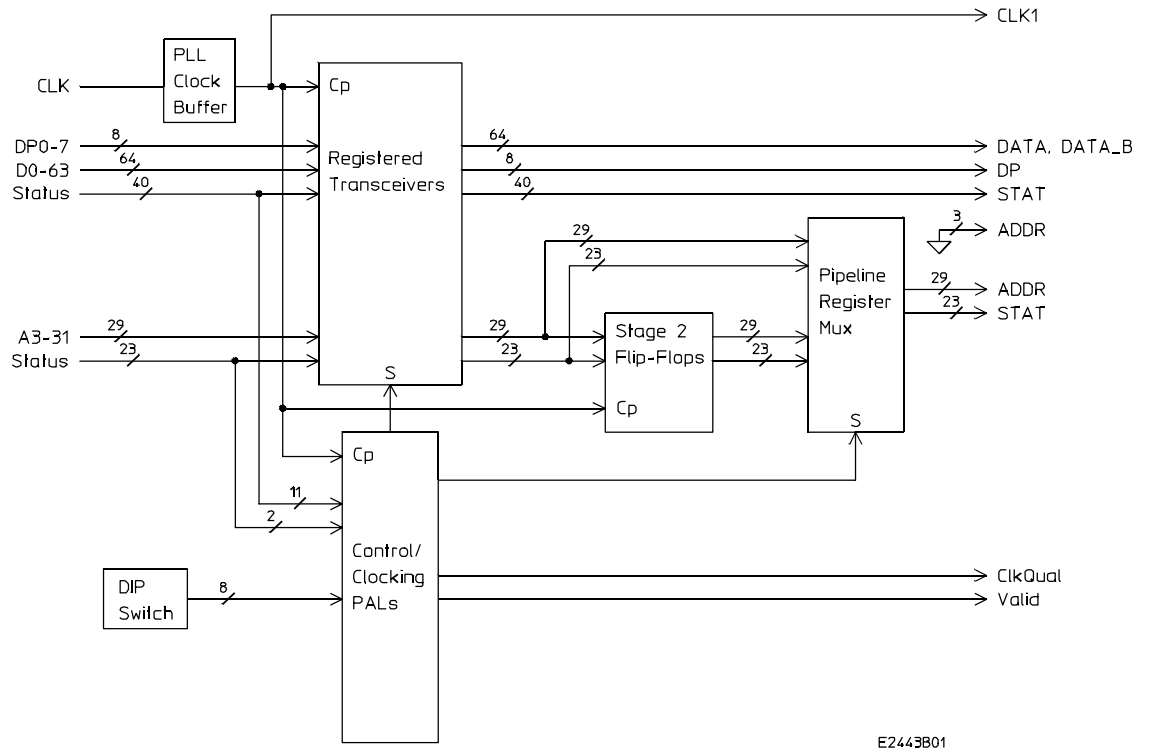

Figure 3-1. HP E2443B Block Diagram



---

## Clocking

The CLK signal is buffered and sent to the logic analyzer on pin 3 of pod 1. For the HP 16550A Logic Analyzer, this is L<sup>↑</sup>; for the HP 1660A and HP 16540/16541A,D Logic Analyzers, this is J<sup>↑</sup>.

If there is no qualification to this clock edge, data is captured on every rising edge of CLK. This method is used in non-qualified State-Per-Clock mode.

The Control/Clocking PALs assert ClkQual to enable the clock qualifier for qualified clocking. For the HP 16550A Logic Analyzer, ClkQual is the M clock; for the HP 1660A and HP 16540/16541A,D Logic Analyzers, it is the K clock. In State-Per-Transfer and Debugger modes, ClkQual is asserted when valid data is on the bus, or when the EADS# qualification signal has been selected and is asserted; in Debugger mode, ClkQual is also asserted whenever IU, IV, or IBT are asserted. In State-Per-Clock mode, ClkQual is asserted when one or more of the six qualification signals has been selected and is asserted.

---

## Pentium CPU Signal to HP E2443B Connector Mapping

Note



The following table describes the electrical interconnections implemented with the HP E2443B Preprocessor Interface. Since the pods on the logic analyzers are numbered differently than the pods on the preprocessor interface, refer to table 1-3 to correlate the pod numbers.

---

The interconnections implemented with the HP E2443B are not direct interconnections. The HP E2443B Preprocessor Interface places digital circuitry between the microprocessor pin and the logic analyzer input.

---

**Table 3-1. Pentium CPU Signal List**

Preprocessor Pod / Pin	Logic Analyzer Probe	Pentium CPU Pin	Pin Mnemonic	Label(s)
P3 / 37	0	*	GND	ADDR
P3 / 35	1	*	GND	ADDR
P3 / 33	2	*	GND	ADDR
P3 / 31	3	T17	A3	ADDR
P3 / 29	4	W19	A4	ADDR
P3 / 27	5	U18	A5	ADDR
P3 / 25	6	U17	A6	ADDR
P3 / 23	7	T16	A7	ADDR
P3 / 21	8	U16	A8	ADDR, ADDR_
P3 / 19	9	T15	A9	ADDR, ADDR_
P3 / 17	10	U15	A10	ADDR, ADDR_
P3 / 15	11	T14	A11	ADDR, ADDR_
P3 / 13	12	U14	A12	ADDR, ADDR_
P3 / 11	13	T13	A13	ADDR, ADDR_
P3 / 9	14	U13	A14	ADDR, ADDR_
P3 / 7	15	T12	A15	ADDR, ADDR_
P4 / 37	0	U12	A16	ADDR, ADDR_
P4 / 35	1	T11	A17	ADDR, ADDR_
P4 / 33	2	U11	A18	ADDR, ADDR_
P4 / 31	3	T10	A19	ADDR, ADDR_
P4 / 29	4	U10	A20	ADDR, ADDR_
P4 / 27	5	U21	A21	ADDR, ADDR_
P4 / 25	6	U9	A22	ADDR, ADDR_
P4 / 23	7	U20	A23	ADDR, ADDR_

\* These signals are generated by the preprocessor interface.

**Table 3-1. Pentium CPU Signal List (Continued)**

<b>Preprocessor Pod / Pin</b>	<b>Logic Analyzer Probe</b>	<b>Pentium CPU Pin</b>	<b>Pin Mnemonic</b>	<b>Label(s)</b>
P4 / 21	8	U8	A24	ADDR, ADDR_
P4 / 19	9	U19	A25	ADDR, ADDR_
P4 / 17	10	T9	A26	ADDR, ADDR_
P4 / 15	11	V21	A27	ADDR, ADDR_
P4 / 13	12	V6	A28	ADDR, ADDR_
P4 / 11	13	V20	A29	ADDR, ADDR_
P4 / 9	14	W5	A30	ADDR, ADDR_
P4 / 7	15	V19	A31	ADDR, ADDR_
P5 / 37	0	D3	D0	DATA
P5 / 35	1	E3	D1	DATA
P5 / 33	2	E4	D2	DATA
P5 / 31	3	F3	D3	DATA
P5 / 29	4	C4	D4	DATA
P5 / 27	5	G3	D5	DATA
P5 / 25	6	B4	D6	DATA
P5 / 23	7	G4	D7	DATA
P5 / 21	8	F4	D8	DATA
P5 / 19	9	C12	D9	DATA
P5 / 17	10	C13	D10	DATA
P5 / 15	11	E5	D11	DATA
P5 / 13	12	C14	D12	DATA
P5 / 11	13	D4	D13	DATA
P5 / 9	14	D13	D14	DATA
P5 / 7	15	D5	D15	DATA

**Table 3-1. Pentium CPU Signal List (Continued)**

<b>Preprocessor Pod / Pin</b>	<b>Logic Analyzer Probe</b>	<b>Pentium CPU Pin</b>	<b>Pin Mnemonic</b>	<b>Label(s)</b>
P6 / 37	0	D6	D16	DATA
P6 / 35	1	B9	D17	DATA
P6 / 33	2	C6	D18	DATA
P6 / 31	3	C15	D19	DATA
P6 / 29	4	D7	D20	DATA
P6 / 27	5	C16	D21	DATA
P6 / 25	6	C7	D22	DATA
P6 / 23	7	A10	D23	DATA
P6 / 21	8	B10	D24	DATA
P6 / 19	9	C8	D25	DATA
P6 / 17	10	C11	D26	DATA
P6 / 15	11	D9	D27	DATA
P6 / 13	12	D11	D28	DATA
P6 / 11	13	C9	D29	DATA
P6 / 9	14	D12	D30	DATA
P6 / 7	15	C10	D31	DATA
P7 / 37	0	D10	D32	DATA_B
P7 / 35	1	C17	D33	DATA_B
P7 / 33	2	C19	D34	DATA_B
P7 / 31	3	D17	D35	DATA_B
P7 / 29	4	C18	D36	DATA_B
P7 / 27	5	D16	D37	DATA_B
P7 / 25	6	D19	D38	DATA_B
P7 / 23	7	D15	D39	DATA_B

**Table 3-1. Pentium CPU Signal List (Continued)**

<b>Preprocessor Pod / Pin</b>	<b>Logic Analyzer Probe</b>	<b>Pentium CPU Pin</b>	<b>Pin Mnemonic</b>	<b>Label(s)</b>
P7 / 21	8	D14	D40	DATA_B
P7 / 19	9	B19	D41	DATA_B
P7 / 17	10	D20	D42	DATA_B
P7 / 15	11	A20	D43	DATA_B
P7 / 13	12	D21	D44	DATA_B
P7 / 11	13	A21	D45	DATA_B
P7 / 9	14	E18	D46	DATA_B
P7 / 7	15	B20	D47	DATA_B
P8 / 37	0	B21	D48	DATA_B
P8 / 35	1	F19	D49	DATA_B
P8 / 33	2	C20	D50	DATA_B
P8 / 31	3	F18	D51	DATA_B
P8 / 29	4	C21	D52	DATA_B
P8 / 27	5	G18	D53	DATA_B
P8 / 25	6	E20	D54	DATA_B
P8 / 23	7	G19	D55	DATA_B
P8 / 21	8	H21	D56	DATA_B
P8 / 19	9	F20	D57	DATA_B
P8 / 17	10	J18	D58	DATA_B
P8 / 15	11	H19	D59	DATA_B
P8 / 13	12	L19	D60	DATA_B
P8 / 11	13	K19	D61	DATA_B
P8 / 9	14	J19	D62	DATA_B
P8 / 7	15	H18	D63	DATA_B

**Table 3-1. Pentium CPU Signal List (Continued)**

Preprocessor Pod / Pin	Logic Analyzer Probe	Pentium CPU Pin	Pin Mnemonic	Label(s)
P1 / 37	0	U4	BE0	STAT, BE#
P1 / 35	1	Q4	BE1	STAT, BE#
P1 / 33	2	U6	BE2	STAT, BE#
P1 / 31	3	V1	BE3	STAT, BE#
P1 / 29	4	T6	BE4	STAT, BE#
P1 / 27	5	S4	BE5	STAT, BE#
P1 / 25	6	U7	BE6	STAT, BE#
P1 / 23	7	W1	BE7	STAT, BE#
P1 / 21	8	T19	IBT	STAT, IBT
P1 / 19	9	J3	KEN#	STAT, KEN#
P1 / 17	10	J4	CACHE#	STAT, CACHE#
P1 / 15	11	N3	W/R#	STAT, W/R#
P1 / 13	12	V4	D/C#	STAT, D/C#
P1 / 11	13	A2	M/IO#	STAT, M/IO#
P1 / 9	14	V3	LOCK#	STAT, LOCK#
P1 / 7	15	U5	A20M#	STAT, A20M#
P2 / 37	0	*	Valid **	STAT, Valid
P2 / 35	1	P4	ADS#	STAT, ADS#
P2 / 33	2	K3	NA#	STAT, NA#
P2 / 31	3	L4	BRDY#	STAT, BRDY#
P2 / 29	4	L3	BRDYC#	STAT, BRDYC#
P2 / 27	5	U3	PRDY	STAT, PRDY
P2 / 25	6	L2	AHOLD	STAT, AHOLD
P2 / 23	7	M3	EADS#	STAT, EADS#

\* This signal is generated by the preprocessor interface.

\*\* Valid = ![!(BRDY# & BRDYC#) & (Pentium CPU in T2, T12, T2P states)]

**Table 3-1. Pentium CPU Signal List (Continued)**

<b>Preprocessor Pod / Pin</b>	<b>Logic Analyzer Probe</b>	<b>Pentium CPU Pin</b>	<b>Pin Mnemonic</b>	<b>Label(s)</b>
P2 / 21	8	W2	HIT#	STAT, HIT#
P2 / 19	9	M4	HITM#	STAT, HITM#
P2 / 17	10	T8	BT0	STAT, BT
P2 / 15	11	W21	BT1	STAT, BT
P2 / 13	12	T7	BT2	STAT, BT
P2 / 11	13	W20	BT3	STAT, BT
P2 / 9	14	K4	BOFF#	STAT, BOFF#
P2 / 7	15	Q3	HLDA	STAT, HLDA
P9 / 37	0	R18	R/S#	R/S#
P9 / 35	1	N4	ADSC#	ADSC#
P9 / 33	2	V5	HOLD	HOLD
P9 / 31	3	V2	BREQ	BREQ
P9 / 29	4	N18	INTR	INTR
P9 / 27	5	N19	NMI	NMI
P9 / 25	6	R4	SCYC	SCYC
P9 / 23	7	T3	BUSCHK#	BUSCHK#
P9 / 21	8	U2	FLUSH#	FLUSH#
P9 / 19	9	A1	INV	INV
P9 / 17	10	A3	EWBE#	EWBE#
P9 / 15	11	M2	WB/WT#	WB/WT#
P9 / 13	12	S3	PWT	PWT
P9 / 11	13	W4	PCD	PCD
P9 / 9	14	L18	RESET	RESET
P9 / 7	15	T20	INIT	INIT

**Table 3-1. Pentium CPU Signal List (Continued)**

Preprocessor Pod / Pin	Logic Analyzer Probe	Pentium CPU Pin	Pin Mnemonic	Label(s)
P10 / 37	0	H4	DP0	DP
P10 / 35	1	C5	DP1	DP
P10 / 33	2	A9	DP2	DP
P10 / 31	3	D8	DP3	DP
P10 / 29	4	D18	DP4	DP
P10 / 27	5	A19	DP5	DP
P10 / 25	6	E19	DP6	DP
P10 / 23	7	E21	DP7	DP
P10 / 21	8	J2	IU	IU
P10 / 19	9	B1	IV	IV
P10 / 17	10	P18	SMI#	SMI#
P10 / 15	11	T5	SMIACT#	SMIACT#
P10 / 13	12	D2	PM0/BP0	PM0/BP0
P10 / 11	13	C3	PM1/BP1	PM1/BP1
P10 / 9	14	B2	BP2	BP2
P10 / 7	15	B3	BP3	BP3
P1 / 5	Clk2**	*	ClkQual	Qual#
P1 / 3	Clk1	K18	CLK	CLK
P2 / 3	Clk1***	*	ClkQual	Qual#
P3 / 3	Clk1***	H3	FERR#	FERR#
P4 / 3	Clk1***	C2	IERR#	IERR#
P5 / 3	Clk1***	S20	IGNNE#	IGNNE#
P6 / 3	Clk1***	M18	PEN#	PEN#
P7 / 3	Clk1***	R3	PCHK#	PCHK#
P8 / 3	Clk1***	P3	AP	AP
P9 / 3	Clk1***	W3	APCHK#	APCHK#
P10 / 3	Clk1***	M19	FRCMC#	FRCMC#

\* These signals are generated by the preprocessor interface.

\*\* HP 16540/16541A,D only.

\*\*\* HP 1660A and HP 16550A only.



---

## Servicing

The repair strategy for the HP E2443B is board replacement. However, table 3-2 lists some mechanical parts that may be replaced if they are damaged or lost. Contact your nearest Hewlett-Packard Sales/Service Office for further information on servicing the board.

Exchange assemblies are available when a repairable assembly is returned to Hewlett-Packard. These assemblies have been set up on the "Exchange Assembly" program. This allows you to exchange a faulty assembly with one that has been repaired, calibrated, and performance verified by the factory. The cost is significantly less than that of a new assembly.

**Table 3-2. Replaceable Parts**

HP Part Number	Description
E2443-69502	Exchange Board/Cable Assembly
E2443-66502	Circuit Board/Cable Assembly
E2443-68703	Software Disk Pouch
1200-1753	Pin Protector
1252-3743	Jumper

---

## Dimensions

Figure 3-2 lists the dimensions for the HP E2443B circuit board. The dimensions are listed in inches and millimeters.

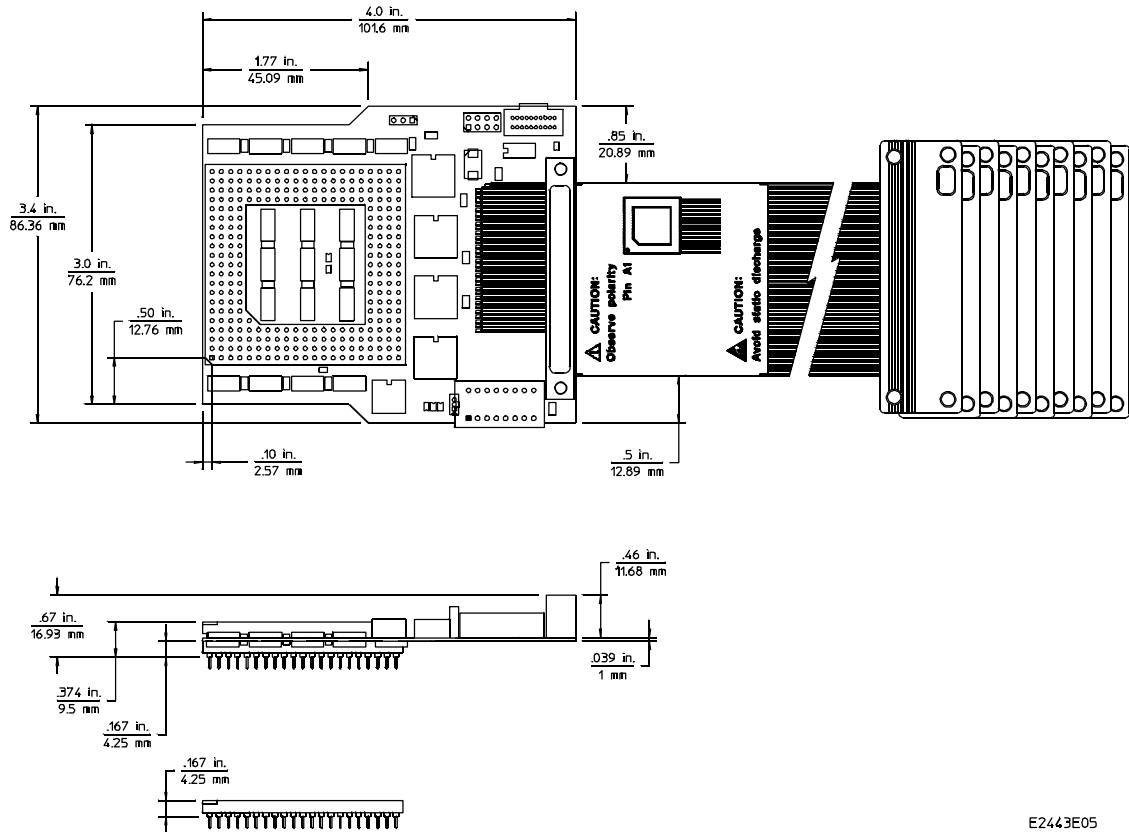

Figure 3-2. HP E2443B Dimensions - inches (mm)

# Troubleshooting

---

If you encounter difficulties while making measurements, use this section to guide you through some possible solutions. Each heading lists a problem you may encounter, along with some possible solutions. Error messages which may appear on the logic analyzer are listed below in quotes ". Symptoms are listed without quotes.

If you are still having difficulties after trying the suggestions below, please contact your local Hewlett-Packard service center for assistance.

## **Target Board Will Not Bootup**

If the target board will not bootup after connecting the preprocessor interface, the microprocessor or the preprocessor interface may not be installed properly, or they may not be making electrical contact.

- Verify that the microprocessor and the preprocessor interface are properly rotated and aligned.
- Verify that the microprocessor and the preprocessor interface are securely inserted into their respective sockets.
- Verify that the logic analyzer cables are in the proper sockets of the preprocessor interface and firmly inserted.
- Reduce the number of extender sockets (see also "Capacitive Loading").

## **Bent Pins**

Bent pins on the preprocessor interface, pin protectors, or adapters can cause system errors or inverse assembly errors. Ensure all pins are properly aligned and making contact.

## **"Slow or Missing Clock"**

This error message might occur if the logic analyzer cards are not firmly seated in the HP 16500A/B or HP 16501A frame. Ensure that the cards are firmly seated.

This error might also occur if the target system is not running properly. Ensure that the target system is on and operating properly.

If the error message persists, check that the logic analyzer pods are connected to the proper connectors, as listed in table 1-3.

**Slow Clock** If you have the preprocessor interface hooked up and running and observe a slow clock or no activity from the interface board, the + 5 V supply coming from the analyzer may not be getting to the interface board.

To check the + 5 V supply coming from the analyzer, disconnect one of the logic analyzer cables from the HP E2443B and measure across pins 1 and 2 or pins 39 and 40 (see figure A-1).

- If + 5 V isn't observed across these pins, check the internal preprocessor fuse or current limiting circuit on the logic analyzer. For information on checking this fuse or circuit, refer to the service manual for your logic analyzer.
- If + 5 V is observed across these pins and you feel confident that the + 5 V is getting to the preprocessor interface, contact your nearest Hewlett-Packard Sales/Service Office for information on servicing the board.

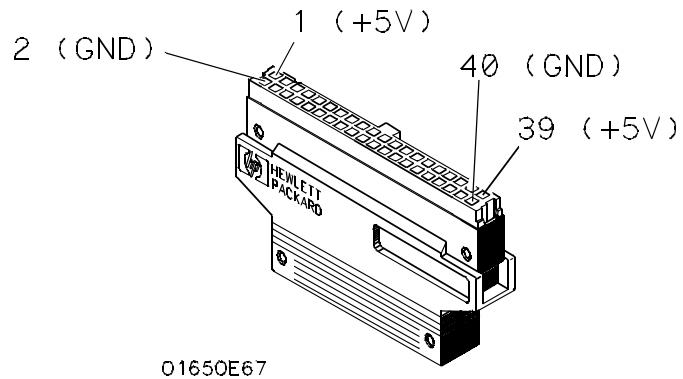

**Figure A-1. Pinout of the Logic Analyzer Cable**

<b>"No Configuration File Loaded"</b>	Verify that the appropriate module has been selected from the Load {module} from File {filename} in the HP 16500A/B disk operation menu. Selecting Load {All} will cause incorrect operation when loading most preprocessor interface configuration files.
<b>"Selected File is Incompatible"</b>	The logic analyzer displays this message if you try to load a configuration file for the wrong module. Ensure that you are loading the appropriate configuration file for your logic analyzer.
<b>". . . Inverse Assembler Not Found"</b>	This error occurs if you rename or delete the inverse assembler file that is attached to the configuration file. Ensure that the inverse assembler file is not renamed or deleted.
<b>No Inverse Assembly</b>	Verify that the inverse assembler has been synchronized by placing an opcode at the top of the display (not at the input cursor) and pressing the Invasm key (see "Inverse Assembler" in Chapter 2).
<b>Incorrect Inverse Assembly</b>	This problem is usually caused by a hardware problem in the target system. A locked status line will often cause incorrect or incomplete inverse assembly. <ul style="list-style-type: none"> <li>• Check the activity indicators for status lines locked in a high or low state.</li> <li>• Verify that the STAT, DATA, DATA_B, and ADDR format labels have not been modified from their default values. These labels must remain as they are configured by the configuration file.</li> <li>• Verify that all microprocessor caches and memory managers have been disabled. In most cases, if the microprocessor caches and memory managers remain enabled you should still get inverse assembly, but it may be incorrect since some of the execution trace was not visible to the logic analyzer.</li> <li>• Verify that storage qualification has not excluded storage of all the needed opcodes and operands.</li> </ul>
<b>No Activity on Activity Indicators</b>	One of the cables, board connections, or preprocessor interface connections is probably loose. Check all connections.

**Capacitive Loading** Excessive capacitive loading can cause signals to degrade, resulting in incorrect capture by the preprocessor interface or system lockup in the microprocessor. All preprocessor interfaces add additional capacitive loading. The following techniques will reduce the capacitive loading:

- Remove as many pin protectors, extenders, and adapters as possible.
- If multiple preprocessor interface solutions are available, try using one with lower capacitive loading.

**Unwanted Triggers** Unwanted triggers can be caused by unexecuted prefetches. Add the prefetch queue depth to the trigger address to avoid this problem.

**"Waiting for Trigger"** If a trigger pattern is specified, this message indicates that the specified trigger pattern did not occur. Verify that the triggering pattern is correctly set.

**Intermittent Data Errors** This problem is usually caused by incorrect signal levels. Adjust the threshold level of the data pod. Use an oscilloscope to check the signal integrity of the data lines, as needed.

**"Time from Arm Greater Than 41.93 ms."** The state/timing analyzers have a counter to keep track of the time from when an analyzer is armed to when it triggers. The width and clock rate of this counter allow it to count for up to 41.93 ms before it overflows. Once the counter has overflowed, the system does not have the data it needs to calculate the time between module triggers. The system must know this time to be able to display data from multiple modules on a single screen.

**No Setup/Hold Field on Format Screen** The HP 16540/16541A,D Logic Analyzer cards are not calibrated. Refer to your logic analyzer reference manual for procedures to calibrate the cards.

**"Default Calibration Factors Loaded" (16540/16541A,D)** The default calibration file for the logic analyzer was loaded. The logic analyzer must be calibrated when using HP 16540A,D and HP 16541A,D cards. Refer to your logic analyzer manual for procedures to calibrate the master clocking system, and ensure that the "cal factors" file is saved.

## **Herstellerbescheinigung**

Hiermit wird bescheinigt, daß das Gerät/System

HP 1650A/B and HP 1651A/B

in Übereinstimmung mit den Bestimmungen von Postverfügung 1046/84 funkentstört ist.

Der Deutschen Bundespost wurde das Inverkehrbringen dieses Gerätes/Systems angezeigt und die Berechtigung zur Überprüfung der Serie auf Einhaltung der Bestimmungen eingeräumt.

Zusatzinformation für Meß- und Testgeräte

Werden Meß- und Testgeräte mit ungeschirmten Kabeln und/oder in offenen Meßaufbauten verwendet, so ist vom Betreiber sicherzustellen, daß die Funk-Entstörbestimmungen unter Betriebsbedingungen an seiner Grundstücksgrenze eingehalten werden.

### **Manufacturer's declaration**

This is to certify that this product HP 1650A/B and HP 1651A/B meets the radio frequency interference requirements of directive Vfg. 1046/84. The German Bundespost has been notified that this equipment was put into circulation and was granted the right to check the product type for compliance with these requirements.

Additional Information for Test- and Measurement Equipment

Note: If test and measurement equipment is operated with unshielded cables and/or used for measurements on open set-ups, the user must insure that under these operating conditions, the radio frequency interference limits are met at the border of his premises.

Note: This declaration indicates compliance of this product with the German RFI specifications stated in the German Vfg. 1046/84 directive.